

Storm VR/VRC2500



Model	VR/VRC2500
VESSEL LENGTH	14–20m 45–64ft
POWER SUPPLY (DC)	12/24V AC Electric available
MOTOR (Watts)	1200
HYDRAULIC PRESSURE	10MPa 1450PSI
HYDRAULIC FLOW	20L/min 5.5gal/min
MAX LOAD	1136kg 2500lb
WORK LOAD	284kg 624lb
AMPS WORK LOAD (DC)	150/70
MAX LINE SPEED	13.5m/min 44ft/min
CHAIN ONLY SIZE	8 mm (5/16") 10 mm (3/8") 13 mm (1/2") (chain only)
ROPE SIZE	14 mm (9/16") 16 mm (5/8")
NET WEIGHT	DC VR 40kg VRC 44kg DC VR 88lb VRC 96lb HYD VR 38kg VRC 42kg HYD VR 84lb VRC 92lb
MANUAL OPERATION	MORS (opt)

Features

- Rope chain combination gypsy
- Quick release integrated swivel chain pipe cover
- Gypsy with capstan (VRC) or gypsy with low profile clutch top arrangement (VR)
- Heavy duty marine grade, dual direction motor in 12 & 24V DC, Hydraulic & AC
- Polished Stainless steel components
- Independent gypsy and capstan operation
- Capstan model features heavy duty fluted finish for increased grip
- Self aligning gearbox/adaptor
- Stainless steel shaft
- Cone clutch/brake
- Stainless steel mounting studs
- Shaft seal
- Lubricating grease nipple
- Clutch release handle
- Rope Chain Management System (RCMS)
- Installation/Operation booklet

Options

- Round base VR/VRC model (chain only)
- AC electric motor available
- Mirror image models available
- Manual Override System (MORS)
- Traditional polished bronze finish
- Extra deck clearance kit for any deck thickness
- Full range of accessories including chain, rope, chain stoppers, snubber kits & devil claws
- Electric & hydraulic operating options & accessories
- Auto anchor - chain counter.



Round base
Muir 2500

VR2500

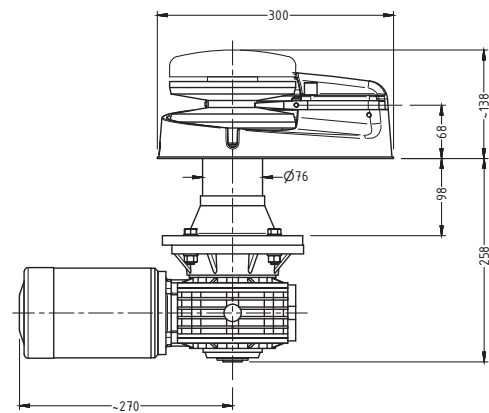
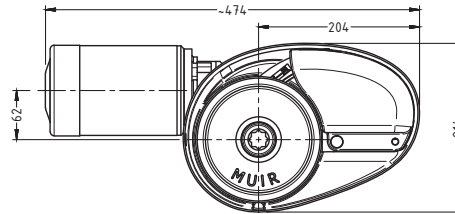

VRC2500

